



K+ SERIES: DSK-3 Triple Deck Steamer

Project: _____ Item: _____



DSK-3

Standard Features:

- AISI 304 Grade Stainless Steel Construction
- Energy efficient heat exchange system
- Insulated heat exchange chamber
- Three Jet Burner fitted with Flame Failure & Auto Ignition
- Overheat tank protector device fitted
- Tank auto refill & Pressure release valve installed
- Three Stop rotary door lock system
- Drain tank valve
- 15-month Warranty
- BWT Best Protect Water Filtration Kit Included to achieve an optimum pH value and an excellent water mineral balance.
- XL Filtration System: QLD, NSW, ACT, VIC, TAS
- 2XL Filtration System: NT, SA, WA

Specifications:

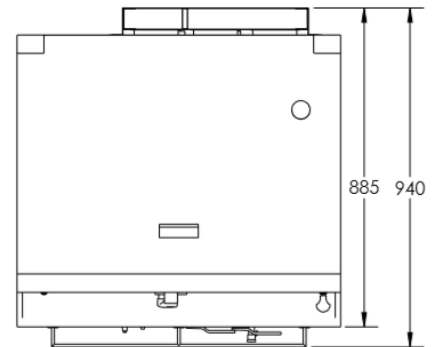
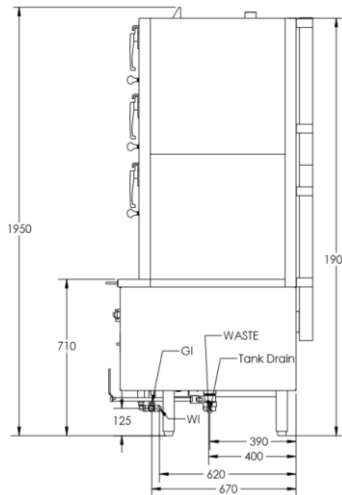
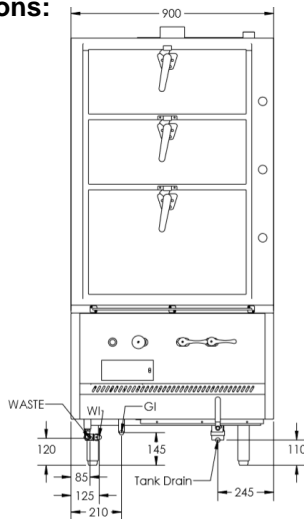

MODEL	LENGTH (mm)	DEPTH (mm)	HEIGHT (mm)	WEIGHT (kg)	GAS CONSUMPTION (Mj/h)	
					NG	LPG
DSK-3	900	885 Unit 940 w/Rail	1950	296	150	150

Connections:

GAS (GI) (BSP)	WATER (WI)	WASTE (BSP)	SUPPLY PRESSURE (kPa)	
			NG	LPG
3/4" (M)	Non-Return Isolating Valve 15 mm Female Flared	1 1/2" (M)	1.0	2.6

- Regulator is included in the unit
- **Must** be installed by an authorised installer
- Warranty **Voided** if water filtration device is not installed

Due to ongoing Product Development, Product Improvement and Research, B+S Commercial Kitchens reserves the right to alter specification without notice.



B+S Commercial Kitchens
57 Plateau Road Reservoir VIC 3073 Australia | +61 3 9469 4754
info@bscommercialkitchens.com | www.bscommercialkitchens.com

