



VERRO SERIES: VCCF-HP1

Single Hole Hi Pac Wok

Project: _____ Item: _____



Standard Features:

- AISI 304 grade stainless steel
- Heavy duty complete stainless-steel cabinet frame
- 165MJ air-forced burner
- No deck cooling required
- Automatic ignition system
- German made pilot and self-diagnostic system
- Patented pilot burner integration system
- Heavy duty lever action gas control allowing easy flame modulation
- Safety flame failure device
- Working status indicator
- Australian made heavy duty tapware
- Ceramic lined heat retention chamber increases cooking speed
- Easy access to all components for servicing and adjustment
- 240V 10-amp, 100 W fan
- 24 month warranty

Options:

- Plinth mounted
- Natural Gas (NG) only

Specifications:

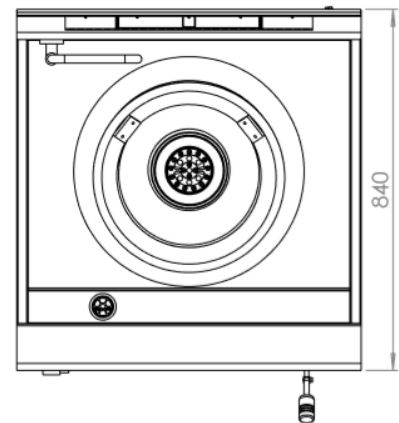
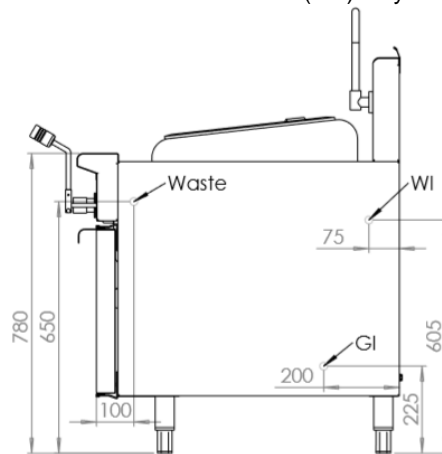
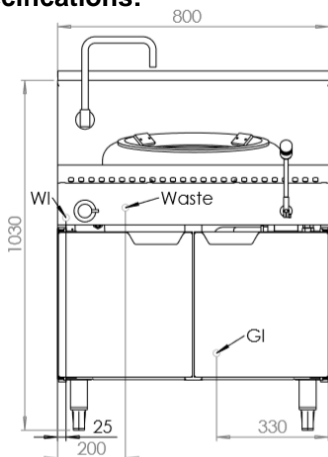

MODEL	LENGTH (mm)	DEPTH (mm)	HEIGHT (mm)	GAS CONSUMPTION (MJ/h)	
				NG	LPG
VCCF-HP1	800	840	1030	165	-

Connections:

GAS (GI) (BSP)	WATER (WI)	WASTE (W) (BSP)	ELECTRICITY (E)	SUPPLY PRESSURE (kPa)
				NG
¾" (M)	½" (Copper)	2" BSP	240V 10 amp, 100W Fan	0.6

- Regulator is included in the unit
- **Must** be installed by an authorised installer

Due to ongoing Product Development, Product Improvement and Research, B+S Commercial Kitchens reserves the right to alter specification without notice.



B+S Commercial Kitchens
 57 Plateau Road Reservoir VIC 3073 Australia | +61 3 9469 4754
 info@bscommercialkitchens.com | www.bscommercialkitchens.com

