

PRODUCT ADVANTAGES



- Compact glasswasher: with an installation height of only 705 mm ideal for narrow places or with integrated reverse osmosis and an installation height of 820 mm ideal for undercounter installation.
- VISIOTRONIC-TOUCH control: single button control with colour code and remaining cycle time indication. With colour display and touch.
- WASHSMART APP: controlling your warewash operation with smart technology: status and messages, usage and operating cost, hygiene, order service and consumables
- 1.9 l rinsing: water consumption per cycle of only 1.9 l which results in a reduction of water, chemicals and energy consumption of 35 %
- CLIP-IN wash and rinse arms: wash and rinse arms can be removed with one hand and without any tools
- Intelligent data documentation: automatic recording of important operational data and consumptions and indication on the display
- USB-interface: comfortable download of operational data in form of a protocol via USB
- GENIUS-X² fine filter system: advanced filter system with pre-wash function reduces detergent consumption up to 35%
- Intensive programme: intensive rinse cycle to wash glasses with critical design with raised fresh-water amount
- Interlocked strainer: prevents operation without tank strainer
- Optional refill signal: monitors contents of external as well as integrated chemical containers
- Hygiene programme: for removal of calcium carbonate and other deposits from wash chamber

TECHNICAL DATA

Cycle times*	60 / 90 / 120 sec. & Continuous (20mins)
Water consumption	1.9 l/rack
Tank capacity	10.6 l
Tank heating	0.8 kW
Power supply	240 / 50 / 1 (415 / 50 / 3N)
Booster loading	
Standard	1.4 kW 15 A
Alternative	6.2 kW 15 A (3phs)
Total loading	
Standard	2.9 kW 15 A
Alternative	7.7 kW 15 A (3phs)
Wash pump	0.6 kW 350 l/min
Rack size	500 x 500 mm
Loading height	305 mm
Noise level	60.5 dB (A)
Weight (gross / net)	70 / 60 kg

*Thermostop guarantees required temperatures with cold water and / or 240 V connection, the actual cycle times extend accordingly.

For machine protection the water hardness should not exceed 3°dH, if higher we recommend using an integrated water softener or an external water softener of the product line HYDROLINE PROTECT.

DIMENSIONAL DRAWING

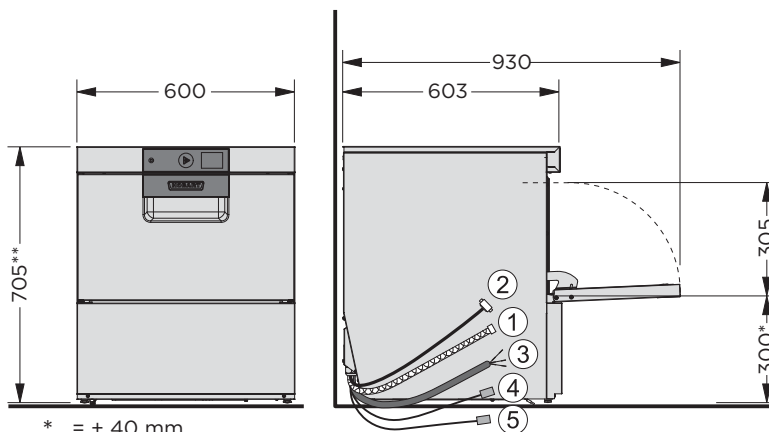

* = + 40 mm

** = 820 mm with integrated osmosis



CONNECTIONS

① Drain hose	2,000 mm ID20/OD25
② Supply hose	2,000 mm R 3/4"
Required flow rate	5 l/min
Flow pressure	0.5 (0.8 with softener)- 6 bar
Max. supply water temperature	60 °C
③ Power cord	2,000 mm
Supply hose for	
④ Detergent	2,500 mm
⑤ Rinse aid	2,500 mm