

C Series Modular Dice Ice Machines – up to 869kg

C 2148 MR Full dice cube 10g, 22mm x 22mm x 22mm



Full Dice Cube 10 g
W 22 x D 22 x H 22 mm



Note: Ice production rate is measured with the water temperature at 10°C and an ambient temperature of 21°C.

- Up to 869kg daily production rate
- Head only ice maker - requires a separate storage bin to store the ice produced
- Requires separate remote condenser
- Air cooled version
- Vertical evaporator spray-system technology
- Agion Technology resists the growth of microbes and the development of unpleasant odours
- One-touch cleaning system
- Electronic control
- Water sense adaptive purge control: saves water by adjusting water usage when is needed
- Simple, reliable electromechanic controls
- Resistant stainless steel exterior
- Easy access front condenser air filter

- External indicator lights to show operation status and maintenance alert
- Includes removable air filter, water and drain hose

Recommended storage bins

- NB 948 – 406kg storage capacity
- UBH 1100 – Upright storage bin with 553kg storage capacity

C Series Modular Dice Ice Machines – up to 869kg

C 2148 MR

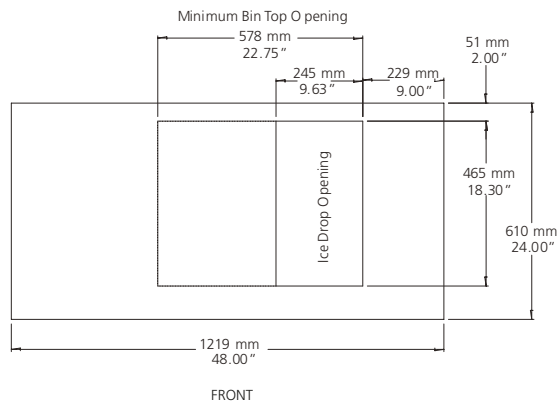
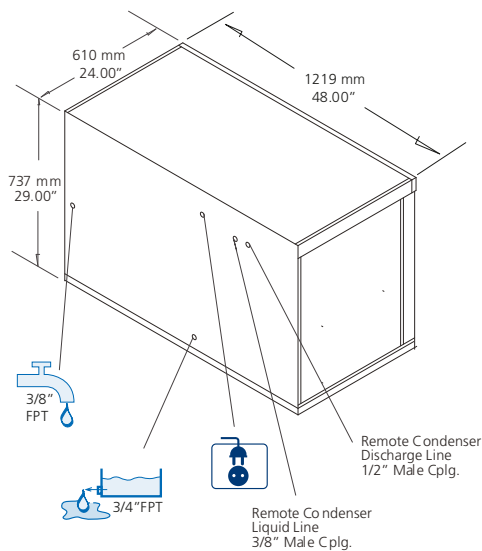

UNIT OF MEASUREMENT: mm



moffat.com.au

Australia
Moffat Pty Limited

Victoria/Tasmania
740 Springvale Road
Mulgrave, Victoria 3170
Telephone 03-9518 3888
Facsimile 03-9518 3833
vsales@moffat.com.au

New South Wales
Telephone 02-8833 4111
nswsales@moffat.com.au

South Australia
Telephone 03-9518 3888
vsales@moffat.com.au

Queensland
Telephone 07-3630 8600
qldsales@moffat.com.au

Western Australia
Telephone 08-9413 2400
wasales@moffat.com.au

Ice production per 24 hours

Ambient temperature / Water temperature

| 10°C / 10°C | 21°C / 10°C | 32°C / 21°C |
|-------------|-------------|-------------|
| 1020 | 869 | 697 |

Dimensions

Width: 1219mm
Depth: 610mm
Height: 737mm
Nett weight: 160kg
Packed weight: 168kg

Water consumption

Air cooled version: 38.5 litres per hour

Electrical rating

Air cooled version: 230-240V, 1P+N+E, 50Hz, 3450W,
25A cordset supplied

No. Circuit wire: 3
Compressor: 3180W
Energy consumption: 8.8kW/hr

Refrigerant type

R404A

Installation distance from wall

Rear 100mm
Operating requirement air temperature 10-43°C

Water connection requirements

Inlet connection: R 3/8"
Cold water: 5-38°C
Pressure: 100-500kPa
Water outlet connection: Ø3/4"

Important Notice:

Models and specifications are subject to change without notice. This spec sheet is meant for commercial purpose only. For technical documentation please refer to our service manuals.



© Copyright Moffat Ltd
AU.SM.1801