

Technical data sheet for

TWIN PAN ELECTRIC FRYER 450mm

E44E

- 17kW high performance twin pan fryer
- 2 digital display temperature controls with 3 product timers each
- Easy clean stainless steel open pan with 10 year limited warranty
- 12L per pan oil capacity
- 25mm (1") drain valves
- Rear rollers
- Stainless steel exterior
- Easy service
- Fully modular



E44E

Overall Construction

- Stainless steel pan
- Bull nose welded 1.5mm 304 stainless steel
- Splashback 1.2mm 304 stainless steel
- Side panels 1.2mm 304 stainless steel
- Double skin door with 0.9mm 304 stainless exterior
- Hinge out counterbalanced heating elements
- 25mm (1") drain valves
- 63mm dia. heavy-duty 1.2mm 304 stainless steel adjustable legs at front and two rollers at rear
- 2 baskets and stainless steel lid supplied standard

Controls

- Digital display electronic thermostats
- Thermostat range 88-193°C
- 3 programmable product timers with countdown display and alarms per pan
- Heating and basket drop displays
- Programmable melt cycles
- Fail-safe over-temperature safety cut-outs
- Element tilt switch for heating cut-out on element lift

Cleaning and Servicing

- Open stainless steel pans with hinge out elements for easy clean
- Easy clean basket support bar
- 25mm (1") drain valves for effective draining
- Easy clean stainless steel exterior
- Access to all parts from front of unit

Technical data sheet for TWIN PAN ELECTRIC FRYER 450mm

Specifications

Production rate
31kg/hr

Pan Size (per pan)
Oil capacity 12L (24lbs shortening)
Width 175mm
Length 380mm
Oil frying depth 95mm

Baskets
2 chrome plated wire baskets
140mm W x 335mm D x 145mm H

Elements (per pan)
3 x 2.83kW stainless steel heating elements

Electrical requirements
17kW, 400-415Vac, 50/60hz, 3P+N+E
L1 23.6A
L2 23.6A
L3 23.6A

Dimensions
Width 450mm
Depth 812mm
Height 915mm
Incl. splashback 1085mm

Nett weight
74kg

Packing data
0.54m³, 116kg
Width 870mm
Depth 495mm
Height 1255mm

Options
Adjustable feet at rear
Filtamax Filtration System
Extra baskets
Side splash guards
Joining caps
Castors

E44E

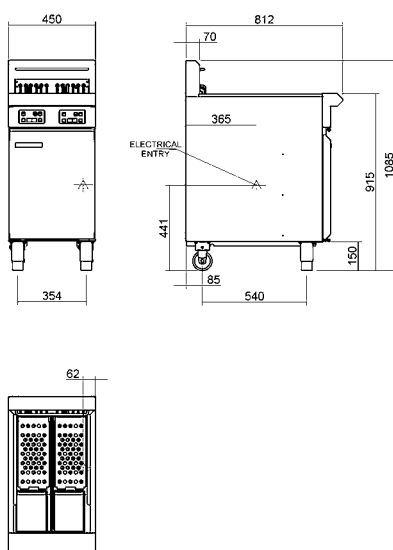

MOFFAT®

Australia
www.moffat.com.au
New Zealand
www.moffat.co.nz

www.bluesealevolution.com

Australia
Moffat Pty Limited

Victoria/Tasmania
740 Springvale Road
Mulgrave, Victoria 3170
Telephone 03-9518 3888
Facsimile 03-9518 3833
vsales@moffat.com.au

New South Wales
Telephone 02-8833 4111
nswsales@moffat.com.au

South Australia
Telephone 03-9518 3888
vsales@moffat.com.au

Queensland
Telephone 07-3630 8600
qldsales@moffat.com.au

Western Australia
Telephone 08-9202 6820
bgarcia@moffat.com.au

New Zealand
Moffat Limited

Christchurch
16 Osborne Street
Christchurch 8011
Telephone 03-389 1007
Facsimile 03-389 1276
sales@moffat.co.nz

Auckland
Telephone 09-574 3150
sales@moffat.co.nz



Designed and manufactured by

MOFFAT®

ISO9001

All Blue Seal products are designed and manufactured by Moffat using the internationally recognised ISO9001 quality management system, covering design, manufacture and final inspection, ensuring consistent high quality at all times.

In line with policy to continually develop and improve its products, Moffat Limited reserves the right to change specifications and design without notice.

Printed in China
© Copyright Moffat Ltd
Moffat / BH / 6860

