

Technical data sheet for

E931M RANGE

GN 1/1 Electric Convection Oven and 4 Element Cooktop



E931M

Unit shall be a Moffat electrically heated Turbofan convection oven and four element cooktop. The cooktop shall have a one piece pressed hygienic stainless steel top with two 2kW high speed hot-plate elements at front and two 1.5kW high speed hot-plate elements at rear. Each element shall be controlled by a 6-heat setting control mounted on a front control panel. The oven shall have capacity for four GN 1/1 pans and include a top grilling oven element and grill operating mode. The oven shall be controlled by a mechanical thermostat 50-270°C and include an over-temperature safety thermostat. A 60 minute mechanical timer with time-up indicator and buzzer shall be included on the control panel. Oven shall have a halogen light. The oven shall be fitted with a 1 phase 15A 3-pin cordset. Cooktop shall provide connection for a 1-phase 32A supply. Unit shall be supplied in 100% recyclable shipping packaging.

STANDARD FEATURES

- Compact 675mm width x 626mm depth
- Single phase 15A plug-in oven
- Single phase connection cooktop

COOKTOP

- Two 2kW high speed front hot-plate elements
- Two 1.5kW high speed rear hot-plate elements
- Full hygienic pressed stainless steel top
- 6-heat setting element controls
- 1-phase 7kW connection

OVEN

- 4 Gastronorm GN 1/1 pan capacity
- 80mm tray spacing
- Mechanical thermostat 50° - 270°C
- 60 minute timer with time-up buzzer
- Grill mode
- Single direction low-velocity fan
- 2.8kW heating in bake mode / 2kW grill elements
- Safe-Touch vented side hinged door (standard LH hinge). Optional RH hinge (field convertible)
- Stay-Cool door handle
- Vitreous enamel oven chamber
- Plug-in continuous oven door seal
- Halogen oven lamp
- 50mm dia. adjustable stainless steel legs
- 4 oven wire racks supplied
- 15A plug-in cordset fitted
- 100% recyclable packaging

E931M GN 1/1 Electric Convection Oven and 4 Element Cooktop

CONSTRUCTION

304 stainless steel hygienic cooktop
 Vitreous enamel fully welded oven chamber
 Stainless steel front, sides and top exterior
 Enamelled steel oven fan baffle and oven vent
 Removable 4 position chrome plated wire side racks
 Oven grids chrome plated wire (4 supplied)
 Stainless steel frame side hinged door
 5mm thick door outer glass
 5mm thick low energy loss door inner glass
 Full stainless steel welded door handle
 Stainless steel control panel
 Aluminised coated steel base and rear panels

CONTROLS - Oven

Oven thermostat 50° - 270°C
 Oven grill setting on thermostat knob
 Power on indicator light
 Heating indicator light
 Mechanical 60 minute timer
 Time-up indicator light and buzzer
 Over-temperature safety cut-out

CONTROLS - Cooktop

6-heat setting control each element
 Hotplate element 'ON' indicator lights

CLEANING

Stainless steel hygienic top
 Stainless steel exterior sides and front
 Vitreous enamel oven chamber
 Fully removable chrome plated oven side racks
 Removable vitreous enamel oven fan baffle
 Easy clean door system with hinge out door inner glass (no tools required)
 Removable plug-in oven door seal (no tools required)
 Full stainless steel legs

SPECIFICATIONS

Electrical Requirements
 OVEN
 230-240V, 50Hz, 1P+N+E, 3.1kW, 12.9A
 15A 3-pin cordset fitted
 COOKTOP
 230-240V, 50Hz, 1P+N+E, 7.0kW, 29.2A
 Supply connection to unit required
 Note - Oven and Cooktop require separate connection

External Dimensions

Width 675mm
 Height 890mm (adjustable 870mm-920mm)
 Depth 626mm

Oven Internal Dimensions

Width 565mm
 Height 425mm
 Depth 395mm
 Volume 0.09m³

Oven Rack Dimensions

Width 540mm
 Depth 370mm

Nett Weight

78.6kg

Packing Data

95kg
 0.54m³
 Width 780mm
 Height 975mm
 Depth 715mm

INSTALLATION CLEARANCES

Rear 25mm
 LH Side 25mm
 RH Side 25mm

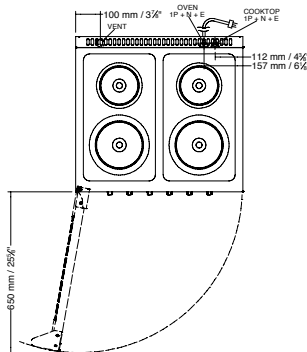
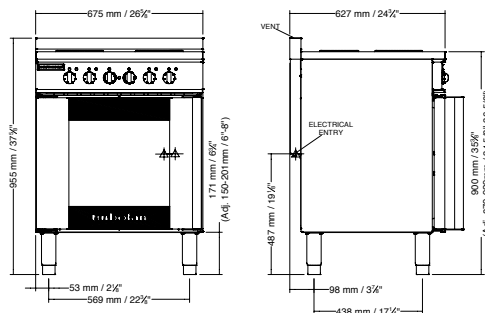

Australia
www.moffat.com.au
 New Zealand
www.moffat.co.nz
www.turbofanoven.com

Australia

Moffat Pty Limited

Victoria/Tasmania
 740 Springvale Road
 Mulgrave, Victoria 3170
 Telephone 03-9518 3888
 Facsimile 03-9518 3833
vsales@moffat.com.au

New South Wales

Telephone 02-8833 4111
nswsales@moffat.com.au

South Australia

Telephone 03-9518 3888
vsales@moffat.com.au

Queensland

Telephone 07-3630 8600
qldsales@moffat.com.au

Western Australia

Telephone 08-9202 6820
bgarcia@moffat.com.au

New Zealand

Moffat Limited

Christchurch
 45 Illinois Drive
 Izone Business Hub
 Rolleston 7675
 Telephone +64 3-983 6600
 Facsimile +64 3-983 6660
sales@moffat.co.nz

Auckland

Telephone 09-574 3150
sales@moffat.co.nz



ISO9001
 Quality
 Management
 Standard

Designed and manufactured by



ISO9001

All Turbofan products are designed and manufactured by Moffat using the internationally recognised ISO9001 quality management system, covering design, manufacture and final inspection, ensuring consistent high quality at all times.

In line with policy to continually develop and improve its products, Moffat Limited reserves the right to change specifications and design without notice.



© Copyright Moffat Ltd
 AN.TFN.S.1501