

MX1LSTS-CF Roll-in Blast Chiller / Freezer

Remote condensing unit version

Standard Features

- Free standing - roll in trolley unit
- Ergonomic touch screen controls
- 5 function home screen
- Manual use – Soft Chill, Hard Chill, Soft Freeze, Hard Freeze and Self Adaptive I-Chilling
- 99 program cycles
- Favourites key – shortcuts to the last 9 programs used
- Pre-chilling cycle key to maximise efficiency
- Multi-point core temperature probe
- Timer mode or continuous run
- Automatic fan stop when opening the door
- Operator selectable de-icing cycle
- External and internal finish made of 304 stainless steel
- Supplied with 20mm insulated stainless steel floor and ramp
- Front frame with anti-condensation system
- Injected polyurethane foam insulation - 80mm thick
- Assembly required

Please refer to Moffat price list for options and accessories

Technical data

Capacity	1 x 1/1GN trolley (trolley not included)
External dimensions	W 1080mm x D 960mm x H 2170mm
Usable internal dimensions	W 650mm x D 790mm x H 1885mm (A1) W 650mm x D 820mm x H 1885mm (A2)
Load capacity	80kg*
Electrical connections	1P+N+E, 230-240V, 50/60Hz, 20A, 2.7kW
Waste	Provide for a water runoff & trap to the selected waste point (B)
Door configuration	Must be stated at time of order
Nett weight	200kg
Remote condensing unit version (remote condensing unit not included)	
Remote condensing unit requirements - Refrigerant type R452A	
Condensing capacity upright Blast Chiller/Freezer	1.6kW / 3.8kW / 7.1kW for the respective evaporation temperatures of -40/-20/-10°C
Remote condensing unit with pump down control	
Ambient temperature requirement	+15°C — +43°C

* Note – Load capacities may vary depending on the thermal conductivity of the food being chilled, the thickness of product and container used

Australia
moffat.com.au

Moffat Pty Limited
740 Springvale Road
Mulgrave
Victoria 3170
Australia
Telephone +613-9518 3888
Facsimile +613-9518 3833
vsales@moffat.com.au

New Zealand
moffat.co.nz

Moffat Limited
45 Illinois Drive
Izone Business Hub
Rolleston 7675
New Zealand
Telephone +64 3-983 6600
Facsimile +64 3-983 6660
sales@moffat.co.nz



Dimensions

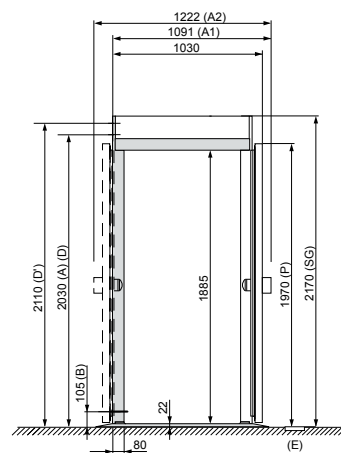
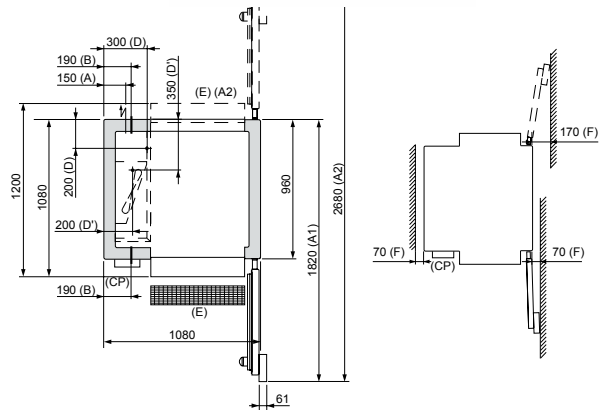

- (A) Electrical supply
- (B) De-icing waste
- (D) Liquid Line 1/2"
- (D') Suction line 1 1/8"
- (CP) Control panel
- (F) Distance from wall
- (E) Floor drain
- (P) Door height
- (DR) Ramp protrusion
- (SG) Overall height
- (A1) Single access
- (A2) Pass through

Alternative door opening configurations available

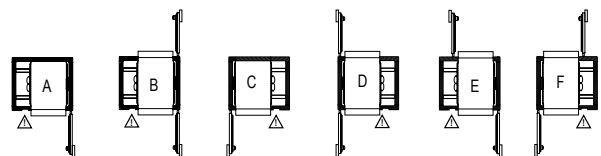

Disclaimer: All unit capacities are based on subjective testing. Moffat accepts no liability for production values.
In line with policy to continually develop and improve its products, Moffat Limited reserves the right to change specifications and design without notice.
© Copyright Moffat Ltd
AN-FRI-S-1801

