

## MX65cATS-CF Roll-in Blast Chiller / Freezer

### Standard Features

- Suitable for direct transfer of 20 GN1/1 Combi oven trolley racks
- Free standing unit on legs
- Ergonomic touch screen controls integrated into the door
- 5 function home screen
- Manual use – Soft Chill, Hard Chill, Soft Freeze, Hard Freeze and Self Adaptive I-Chilling
- 99 program cycles
- Favourites key – shortcuts to the last 9 programs used
- Pre-chilling cycle key to maximise efficiency
- Multi-point core temperature probe
- Timer mode or continuous run
- Automatic fan stop when opening the door
- Operator selectable de-icing cycle
- External and internal finish made of 304 stainless steel
- Front frame with anti-condensation system
- Injected polyurethane foam insulation - 60mm thick

Please refer to Moffat price list for options and accessories

### Technical data

Trolley Capacity	1 x 20 1/1GN Combi trolley
External dimensions	W 850mm x D 790mm x H 2420mm
Load Capacity	85kg*
Electrical connections	3P+N+E, 400-415V, 50/60Hz, 20A, 4.0kW
Nett weight	210 kg
Waste	Provide for a water runoff with trap
Air-cooled condensing unit - Refrigerant type	R452A
Ambient temperature requirement	+15°C — +32°C

\* Note – Load capacities may vary depending on the thermal conductivity of the food being chilled, the thickness of product and container used



### Dimensions

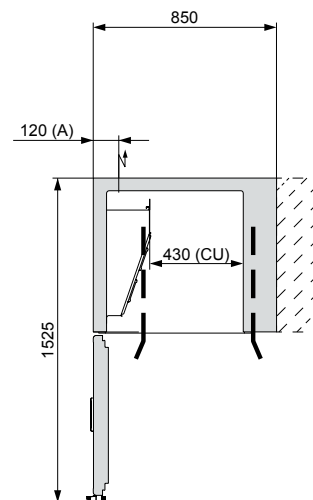
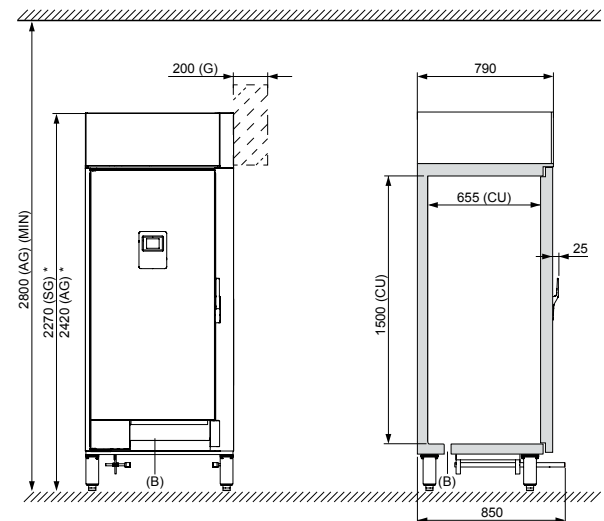

- (A) Electrical supply
- (B) De-icing waste
- (CU) Useful
- (MIN) Minimum

Australia	New Zealand
<a href="http://moffat.com.au">moffat.com.au</a>	<a href="http://moffat.co.nz">moffat.co.nz</a>
<b>Moffat Pty Limited</b> 740 Springvale Road Mulgrave Victoria 3170 Australia Telephone +613-9518 3888 Facsimile +613-9518 3833 vsales@moffat.com.au	<b>Moffat Limited</b> 45 Illinois Drive Izone Business Hub Rolleston 7675 New Zealand Telephone +64 3-983 6600 Facsimile +64 3-983 6660 sales@moffat.co.nz

Disclaimer: All unit capacities are based on subjective testing. Moffat accepts no liability for production values. In line with policy to continually develop and improve its products, Moffat Limited reserves the right to change specifications and design without notice.

© Copyright Moffat Ltd  
AN-FRI-S-1801



an Ali Group Company



The Spirit of Excellence