

Technical data sheet for

TARGET TOP GAS / ELECTRIC CONVECTION OVEN RANGE 900mm

RN8110GEC



- Heavy-duty cast iron top with removable centre ring
- Matched modular height machined top for seamless work surface
- High output dual ring cast iron burner
- GN 2/1 6.6kW electric convection oven
- Drop down door
- Stainless steel exterior
- Easy clean
- Easy service
- Fully modular
- Low back model (RNL) available

Overall Construction

- Galvanized steel chassis
- Welded hob surround with 1.5mm 304 stainless steel bull nose
- Splashback and hob sides 1.2mm 304 stainless steel
- Front panels and oven sides 0.9mm 304 stainless steel
- 150mm legs in 63mm dia. heavy-duty 1.2mm 304 stainless steel with adjustable feet

TARGET TOP

- 3 piece heavy-duty cast iron top with fully machined surface
- Top plates and removable centre with integral spill protection design
- Cast top reinforced with integral heat fins for heat zone definition
- 45MJ dual ring cast iron burner with single control
- Full pilot and flame failure protection
- 50mm thick refractory brick lined burner box for high heat retention
- 2 vitreous enamelled spill trays
- Supplied with heavy-duty centre casting removal tool

OVEN

- Fully welded and vitreous enamelled oven liner
- GN 2/1 capacity with 4 position racking
- Heavy-duty easy remove heavy wire chrome rack supports
- Cast iron even heat oven sole plate
- 6.5kW heating elements
- 100W heavy-duty motor
- 200mm diameter heavy-duty circulation fan
- Welded frame drop down door with heavy-duty spring hinge system
- 0.9mm 304 stainless steel door outer
- 1.0mm press formed vitreous enamelled door inner
- High density fibreglass insulated
- Stay cool stainless steel door handle with cast metal handle mounts
- Supplied with two chrome wire oven racks

Controls

- Large easy use control knobs - heat resistant reinforced
- Easy view control settings on knobs

TARGET TOP

- Variable high to low burner control
- Single control knob for burner and pilot system
- Flame failure pilot burner
- Manual pilot ignition for reliable operation

OVEN

- 50-320°C thermostatic control
- Indicator lights for power and heating

Cleaning and Servicing

- Removable oven racking and sole plate
- Easy clean vitreous enamel oven and door inner
- Easy clean stainless steel exterior
- Fully serviceable from front unit
- Door hinge spring adjustable on unit (door outer removed)
- Door disengages for lift off removal and increased service access
- All parts front accessible from installed position

Technical data sheet for

TARGET TOP GAS / ELECTRIC CONVECTION OVEN RANGE 900mm

Specifications

Burners

45MJ dual ring cast iron - Target Top

Oven Elements

4.5kW bottom heat element

2.0kW top heat element

Oven Fan Motor

100W

Gas power

45MJ/hr, 16.2kW

Electrical requirements

6.6kW

1 phase connection:

230-240Vac, 50/60Hz, 1P+N+E, 27.7A

3 phase connection:

400-415Vac, 50/60Hz, 3P+N+E

L1 9.4A

L2 9.4A

L3 9.0A

Target Top

Cooking surface 900mm x 625mm, 5625cm²

Centre 280mm diameter

Maximum plate temperature at centre 500°C

Oven Dimensions

Width 665mm

Depth 590mm

Height 385mm

Rack size 660mm x 540mm

Rack positions 4

Gas connection

R 3/4 (BSP) male

130mm from RH side, 31mm from rear,
and 655mm from floor

Optional underside connection
(refer specification drawing)

All units supplied with Natural and LP gas
regulator

Electrical connection

25mm from RH side, 484mm from rear,
and 150mm from floor

DIMENSIONS

Width 900mm

Depth 805mm

Height 915mm

Incl. splashback 1130mm

Incl. low back 970mm

NETT WEIGHT

275kg

PACKING DATA

1.03m³, 340kg

Width 945mm

Depth 870mm

Height 1255mm

GAS TYPES

Available in Natural gas and LP gas

Please specify when ordering

Units supplied complete with gas type
conversion kits

Other gas types on request

OPTIONS AT EXTRA COST

Joining caps

Castors

Plinth mounting

RN8110GEC

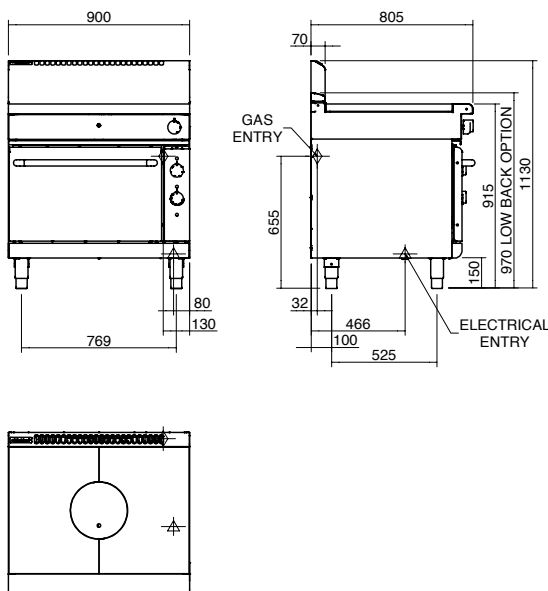

Waldorf
800 SERIES

MOFFAT

Australia
www.moffat.com.au
New Zealand
www.moffat.co.nz

Australia
Moffat Pty Limited

Victoria/Tasmania
740 Springvale Road
Mulgrave, Victoria 3170
Telephone 03-9518 3888
Facsimile 03-9518 3833
vsales@moffat.com.au

New South Wales
Telephone 02-8833 4111
nswsales@moffat.com.au

South Australia
Telephone 03-9518 3888
vsales@moffat.com.au

Queensland
Telephone 07-3630 8600
qldsales@moffat.com.au

Western Australia
Telephone 08-9202 6820
bgarcia@moffat.com.au

New Zealand
Moffat Limited

Christchurch
Telephone 03-389 1007
sales@moffat.co.nz

Auckland
Telephone 09-574 3150
sales@moffat.co.nz



Designed and manufactured by

MOFFAT

ISO9001
All Waldorf products are designed and
manufactured by Moffat using the
internationally recognised ISO9001 quality
management system, covering design,
manufacture and final inspection, ensuring
consistent high quality at all times.



In line with policy to continually develop and
improve its products, Moffat Limited reserves
the right to change specifications and design
without notice.

Printed in New Zealand
© Copyright Moffat Limited
Moffat/BH/6864

