

*Customized
Caster H=115mm
Power Cord Australian 3 Pin Plug

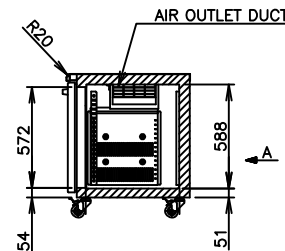
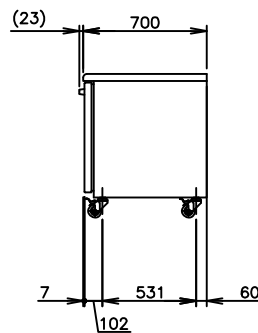
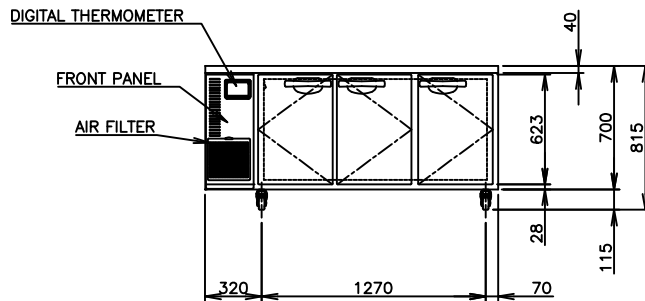
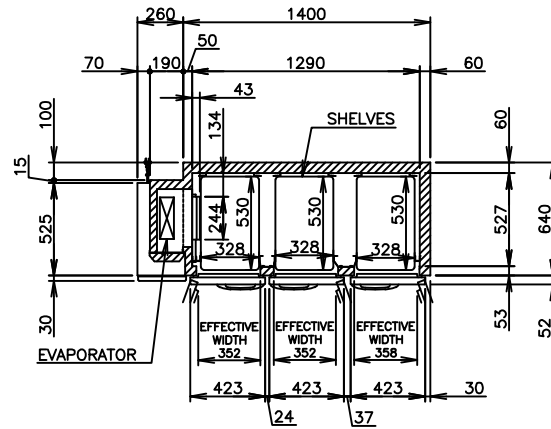
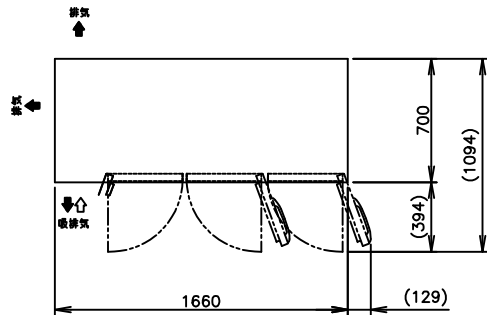

ITEM	Hoshizaki Undercounter Refrigerator
MODEL	RTE-170SDA-GN
POWER SUPPLY	1 Phase 220-240V 50Hz Capacity:0.43kVA(1.9A)
AMPERAGE	Rated 1.4A Starting 6.8A
ELECTRIC CONSUMPTION	Motor 195W(Power Factor65%) Heater 193W Refrigeration 223W Defrost 200W
HEAT REJECTION	300W
POWER CORD	2.5m (Plug with Earth Wire)
EFFECTIVE CAPACITY	412L
OUTSIDE DIMENSIONS	W1660×D700×H815mm
INSIDE DIMENSIONS	W1290×D527×H588mm
EXTERIOR	Stainless Steel, Galvanized Steel (Rear/Bottom)
INTERIOR	Stainless Steel, ABS Plastic
INSULATION	Polyurethane Foam
REFRIGERATION SYSTEM	Forced Air Circulation
DEFROST SYSTEM	Glass Tube Heater
COMPRESSOR	Hermetic 110W
CONDENSER	Fin and Tube type, Air-cooled
EVAPORATOR	Fin and Tube Type
REFRIGERANT	R134a
TEMPERATURE CONTROL	Microprocessor controlled Adjustable from -6 to 12℃
DEFROST CONTROL	Microprocessor controlled
ELECTRIC CIRCUIT PROTECTION	10A Fuse, Earth Wire
COMPRESSOR PROTECTION	Motor Protector
LEG	Urethane (76mm DIA 115mm HIGH)
WEIGHT	Net:103kg (Gross: Approx. **kg)
PACKAGE	Carton (Wooden Pallet) 1735mm(W) x 780mm(D) x 990mm(H)
ACCESSORIES	Shelf x 6, Rail x 12
OPERATING CONDITIONS	Ambient Temperature:5-43℃ Voltage Range:Rated Voltage±6%

*We reserve the right to make changes in specifications and design without prior notice.

1. Install the product properly in accordance with the instructions on location, electrical connections stated in the instruction manual provided. Allow 10mm extra space at the installation site to meet any installation requirements(additional spacing is also required for proper air flow).
2. The heat rejection is based on the reached pulldown temperature at ambient temperature of 43℃ and power supply of 230V 50Hz. The ampereage and electric consumption are based on measurements at ambient temperature of 43℃ and power supply of 230V 50Hz.
3. The cabinet temperature range of -6 to 12℃ is guaranteed at ambient temperature of 30℃.
4. Product Code : T040-D008

HOSHIZAKI UNDERCOUNTER REFRIGERATOR RTE-170SDA-GN (FOR HLP)

*	*	△	****	DATE	DRAWING NO.	SYMBOL
APPROVED	DESIGNED	SYMBOL	DATE	2018.02.09	D21966	△