

ITEM	Hoshizaki Reach-in Freezer
MODEL	HFE-187B-CHD
POWER SUPPLY	1 Phase 220 - 240V 50Hz Capacity: 1.26kVA (5.5A)
AMPERAGE	Rated: 3.79A Starting: 20.0A
ELECTRIC CONSUMPTION	723W (Power Factor: 83%) Heater: 725W Defrost: 725W
HEAT REJECTION	1330W
POWER CORD	2.3m (Plug with Earth Wire)
EFFECTIVE CAPACITY	1713L
△ OUTSIDE DIMENSIONS	1800mm(W)×800mm(D)×1990(-2020)mm(H)
INSIDE DIMENSIONS	1696mm(W)×648mm(D)×1484mm(H)
EXTERIOR	Stainless Steel, Galvanized Steel(Rear, Bottom)
INTERIOR	Stainless Steel, ABS Plastic(Door)
INSULATION	Polyurethane Foam
△ INSULATION FOAM BLOWING AGENT	Cyclopentane
REFRIGERATION SYSTEM	Forced Air Circulation
DEFROST SYSTEM	Heater
COMPRESSOR	Hermetic 700W
CONDENSER	Fin and Tube type, Air-cooled
EVAPORATOR	Fin and Tube type
REFRIGERANT	R404A
TEMPERATURE CONTROL	Microprocessor (Digital Temp. Indication) Adjustable from -25 to -7℃
DEFROST CONTROL	Microprocessor
ELECTRIC CIRCUIT PROTECTION	Earth Wire, Circuit Breaker
REFRIGERANT CIRCUIT PROTECTION	Motor Protector (Auto-reset)
LEG	Plastic Adjustable from 90 to 120mm
SHELF	12 pcs.
WEIGHT	213kg (Gross 260kg)
PACKAGE	Carton (Wooden Pallet) 1860mm(W)×900mm(D)×2075mm(H)
ACCESSORIES	Drain Hose×1
OPERATING CONDITIONS	Ambient Temperature: 5 - 43℃ Voltage Range: Rated Voltage ±6%

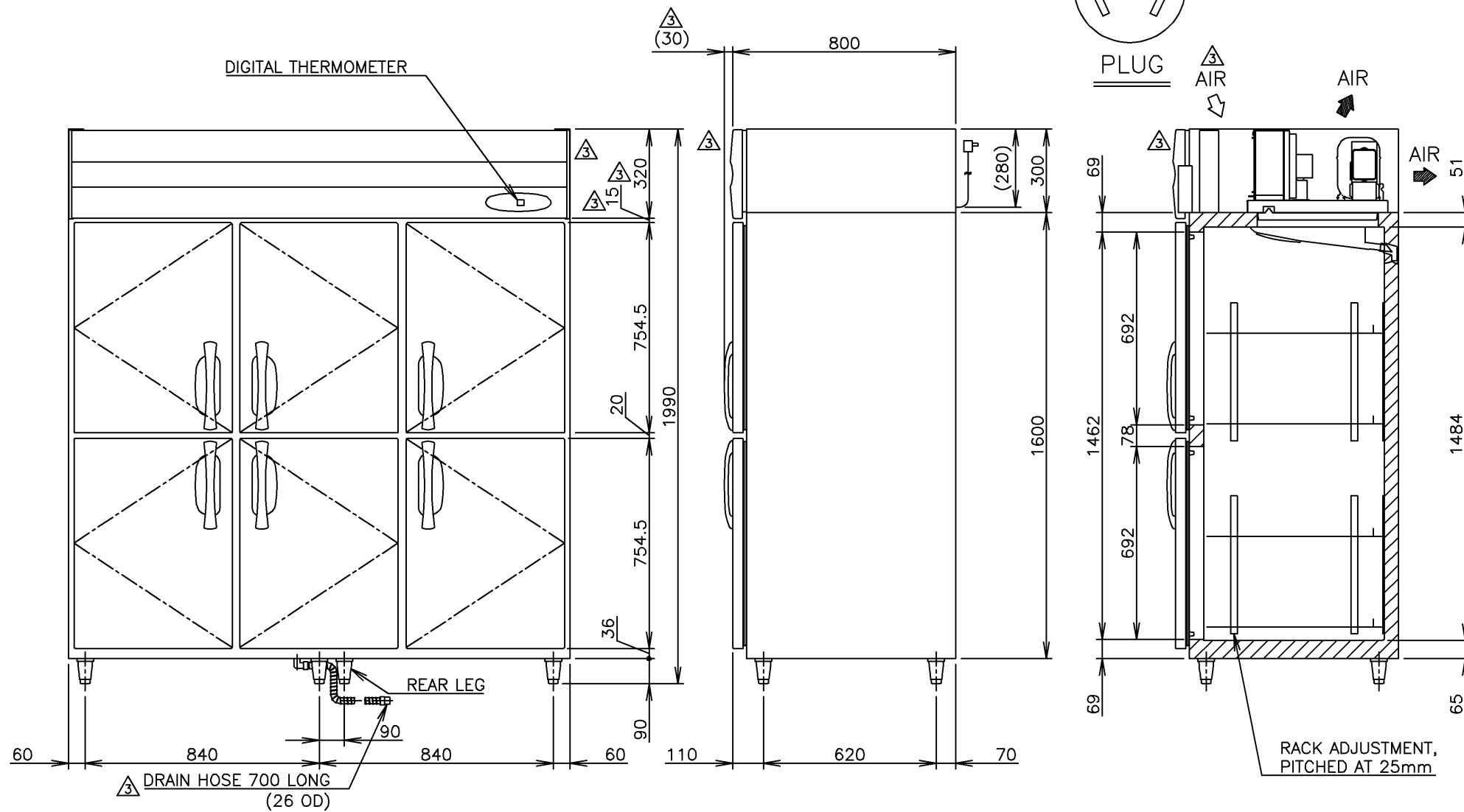

\*We reserve the right to make changes in specifications and design without prior notice.

1. Install the product properly in accordance with the instructions on location, water supply/ drain connections and electrical connections stated in the instruction and installation manuals provided.  
Allow 10mm extra space at the installation site to meet any installation requirements (additional spacing is also required for proper air flow and pipe connections).
2. The heat rejection is based on the reached pulldown temperature at ambient temperature of 43℃.
3. Product Code: R113

# HOSHIZAKI REACH-IN FREEZER HFE-187B-CHD

APPROVED ISHIGURO	CHECKED TAKAOKA	DESIGNED NISHIO	DRAWN MINEZAWA	SCALE 1/20	TRIGONOMETRY
ISHIGURO	KATO	2011.04.27	DATE 2010.04.29	DRAWING NO. D06669	SYMBOL △3
APPROVED	DESIGNED	SYMBOL	DATE		