



MIXER ELECTRIC 20 QUART

MODEL:
PMA1020

NOTE:

When viewing the appliance from the front in its usual operating position, the width (W) of the product is the total distance from left to right ; the depth (D) of the product is the total distance from front to back ; the height (H) is the total distance from the bottom of the product to the top.

MIXING BOWL
XPMA 0078



SPATULA
XPMA 0079



DOUGH HOOK
XPMA 0080



WIRE WHISK
XPMA 0081

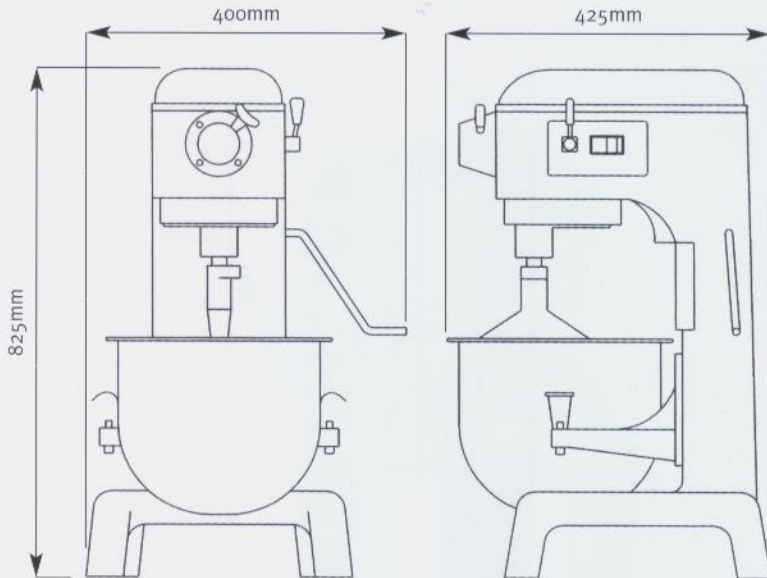

DESCRIPTION	MIXER 20QT WITH GUARD	DESCRIPTION OF ACCESSORIES
MODELS	PMA 1020	MIXING BOWL XPMA0078
POWER (HP)	0.5	SPATULA XPMA0079
VOLTAGE (V)	240V	DOUGH HOOK XPMA0080
DIMENSIONS (mm) (W x D x H)	400 x 425 x 825	WIRE WHISK XPMA0081
BOX DIMENSIONS (mm) (W x D x H)	575 x 475 x 1000	
SHIPPING WEIGHT (kg)	100	
PLANETARY SPEED	106 / 359 / 397 rpm	

Note: Output performance figures quoted are dependant on various factors.

DISTRIBUTED BY:

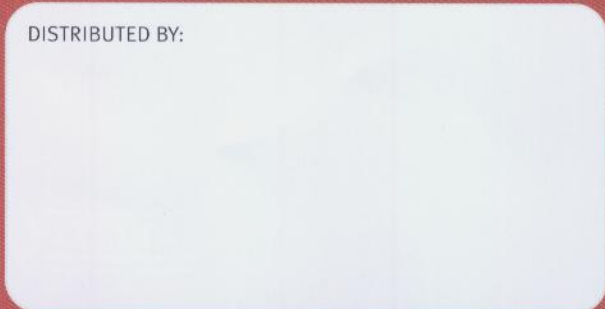

MIX_ANVIL_USA_07

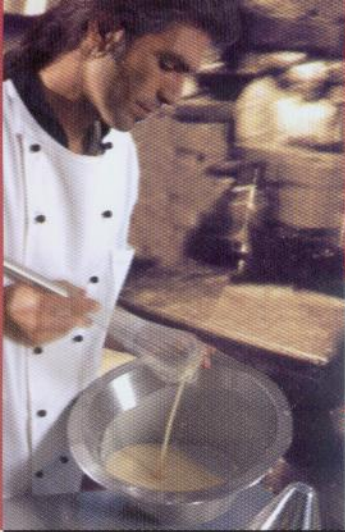

 **ANVIL**

MIXER ELECTRIC

GOLD SERIES - DIRECT DRIVE GEAR TRANSMISSION - 20 QUART

MIXER ELECTRIC 20 QUART



"Anvil's 20 Quart Mixers are designed specifically for small commercial mixing applications. The grease packed ball bearing and air cooled motor ensure quiet and efficient continuous operation."

APPLICATION

- IDEAL FOR CONVENIENCE STORES, SMALL BAKERIES AND HOME INDUSTRIES
- COMES STANDARD WITH MIXING BOWL, WIRE WHISK, DOUGH HOOK AND SPATULA. THESE ITEMS ARE ALSO AVAILABLE SEPARATELY
- CONSISTENT MIXING SPEEDS ARE MAINTAINED REGARDLESS OF THE VOLUME IN THE BOWL DUE TO THE DIRECT DRIVE TRANSMISSION SYSTEM

CONSTRUCTION

- POWERFUL 1/2HP AIR COOLED MOTOR
- 3 FIXED SPEEDS WITH EASY SPEED SHIFTING
- DIRECT DRIVE 100% GEAR DRIVEN TRANSMISSION
- LONG-LIFE GEAR BOX
- #12 HUB FOR A MEAT GRINDING ATTACHMENT OFFERS FLEXIBILITY BETWEEN GRINDING AND MIXING
- GREASE PACKED BALL BEARING
- 240V SINGLE PHASE
- SAFETY GUARD WITH INGREDIENT CHUTE STANDARD
- GEARS AND SHAFTS MADE OF HEAT TREATED ALLOY STEEL

Anvil reserves the right, without notice, to make changes and revisions to product specifications, materials and design, which in our opinion, will provide better performance, durability and efficiency.

QUALITY  GUARANTEE

ALL ANVIL EQUIPMENT COMES WITH A ONE YEAR WARRANTY ON COMPONENTS AND DEFECTIVE WORKMANSHIP