

1. Install the product properly in accordance with the instructions on location, electrical connections stated in the instruction manual provided. Allow 10mm extra space at the installation site to meet any installation requirements (additional spacing is also required for proper air flow and pipe connections).
2. The heat rejection is based on the reached pulldown temperature at ambient temperature of 32°C and power supply of 230V 50Hz. The amperage and electric consumption are based on measurements at ambient temperature of 32°C and power supply of 230V 50Hz.
3. The cabinet temperature range of -6 to 12°C is guaranteed at ambient temperature of 30°C.
4. Product code: T014-C804

ITEM	Hoshizaki Drawer Type Undercounter Refrigerator
MODEL	RTC-167DEA-GN-9D
POWER SUPPLY	1 Phase 220-240V 50Hz Capacity: 0.54kVA(2.5A)
AMPERAGE	Rated: 2.2A
ELECTRIC CONSUMPTION	Motor: *W(Power Factor: *%) Heater: 218W Refrigeration: *W Defrost: 218W
HEAT REJECTION	*W
POWER CORD	2.3m (Plug with Earth Wire)
EFFECTIVE CAPACITY	404L
OUTSIDE DIMENSIONS	1670mm(W) x 700mm(D) x 815mm(H)
INSIDE DIMENSIONS	1300mm(W) x 533mm(D) x 588mm(H)
EXTERIOR	Stainless Steel, Galvanized Steel (Rear/Bottom)
INTERIOR	Stainless Steel, ABS Plastic
INSULATION	Polyurethane Foam
INSULATION FOAM BLOWING AGENT	Cyclopentane
REFRIGERATION SYSTEM	Forced Air Circulation
DEFROST SYSTEM	Glass Tube Heater
COMPRESSOR	Hermetic 215W
CONDENSER	Fin and Tube type, Air-cooled
EVAPORATOR	Fin and Tube Type
REFRIGERANT	R134a/150g
TEMPERATURE CONTROL	Microprocessor (Digital Temp Indication) Adjustable from -6 to 12°C
DEFROST CONTROL	Microprocessor Controlled
ELECTRIC CIRCUIT PROTECTION	Fuse, Earth Wire
REFRIGERANT CIRCUIT PROTECTION	Motor Protector
LEG	Urethane (76mm DIA, 115mm HIGH)
WEIGHT	151kg (Gross Approx. *kg)
PACKAGE	Carton 1735mm(W) x 780mm(D) x 950mm(H)
OPERATING CONDITIONS	Ambient Temperature: 5-43°C Voltage Range: Rated Voltage±6%

*We reserve the right to make changes in specifications and design without prior notice.

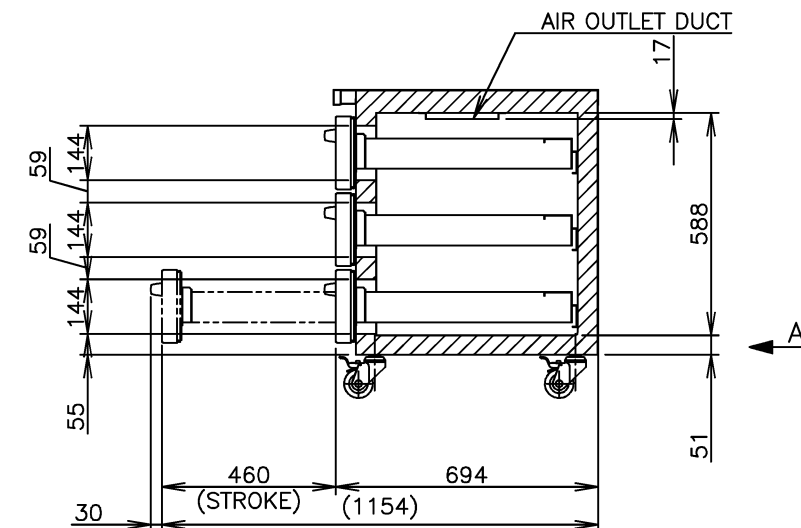
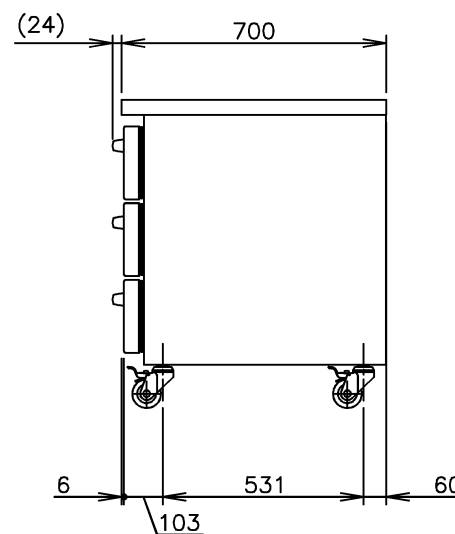
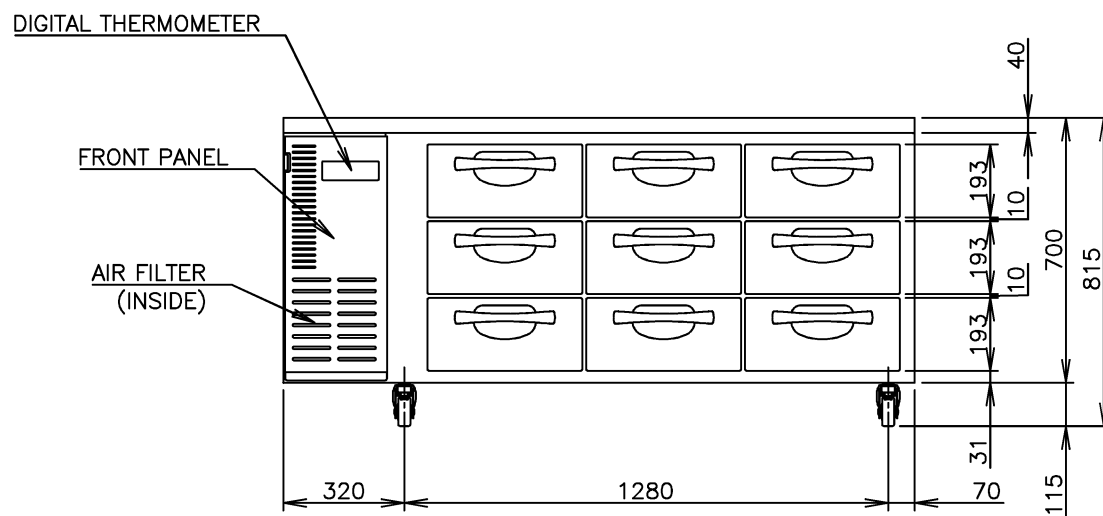
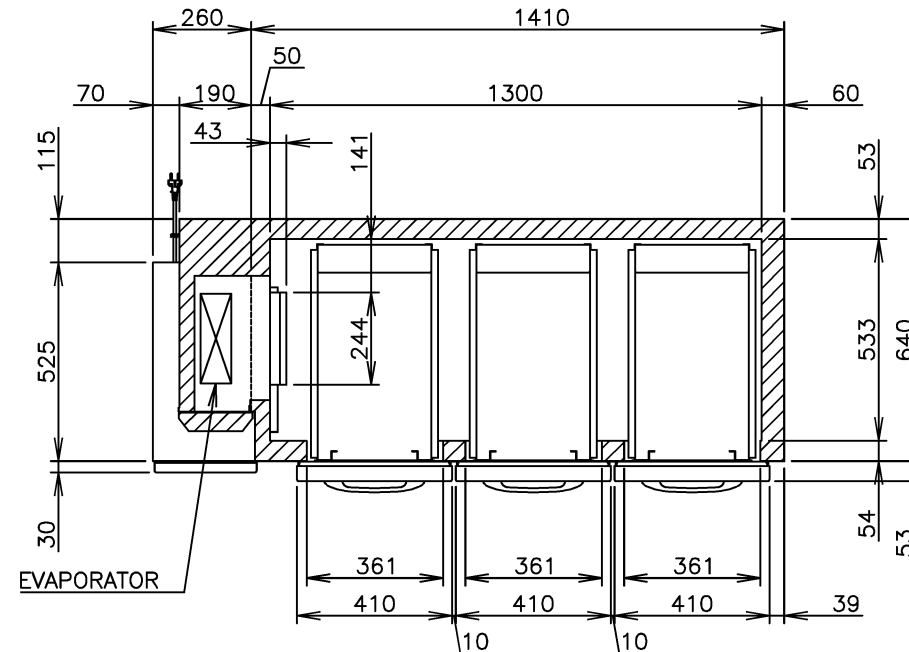
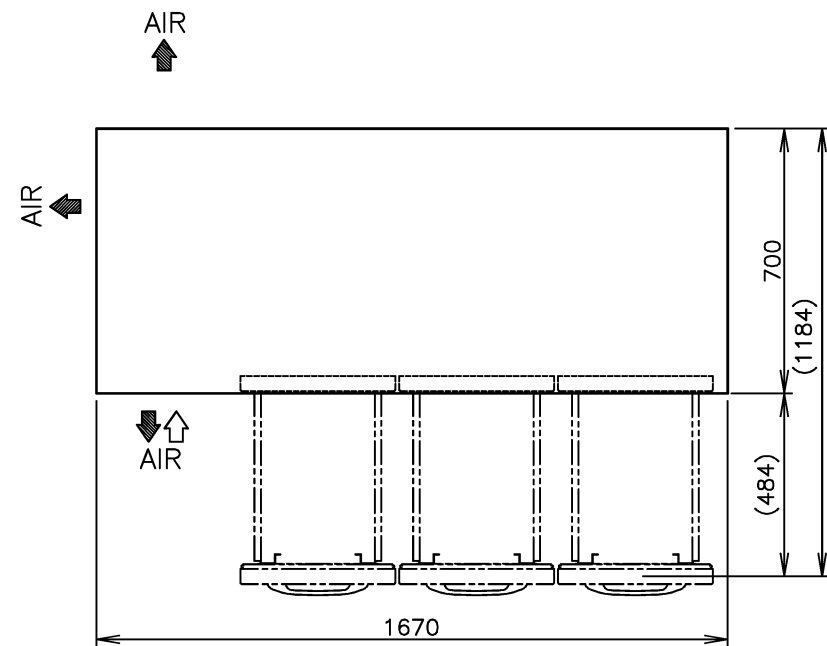

HOSHIZAKI DRAWER TYPE UNDERCOUNTER REFRIGERATOR RTC-167DEA-GN-9D

APPROVED KAWAKAMI	CHECKED WANG	DESIGNED LIU	DRAWN ZHANG	SCALE 1/20	TRIGONOMETRY
*	*	△	*	DATE 2019.02.15	DRAWING NO. D24513
APPROVED	DESIGNED	SYMBOL	DATE		SYMBOL