



HOSHIZAKI

RTL-98DDAC

Lowboy Undercounter Refrigeration

PRODUCT FEATURES

- Stainless steel
- Forced air circulation refrigeration system
- Automatic defrost
- Auto closing drawers
- 2 and 4 drawer options

TECHNICAL DRAWING

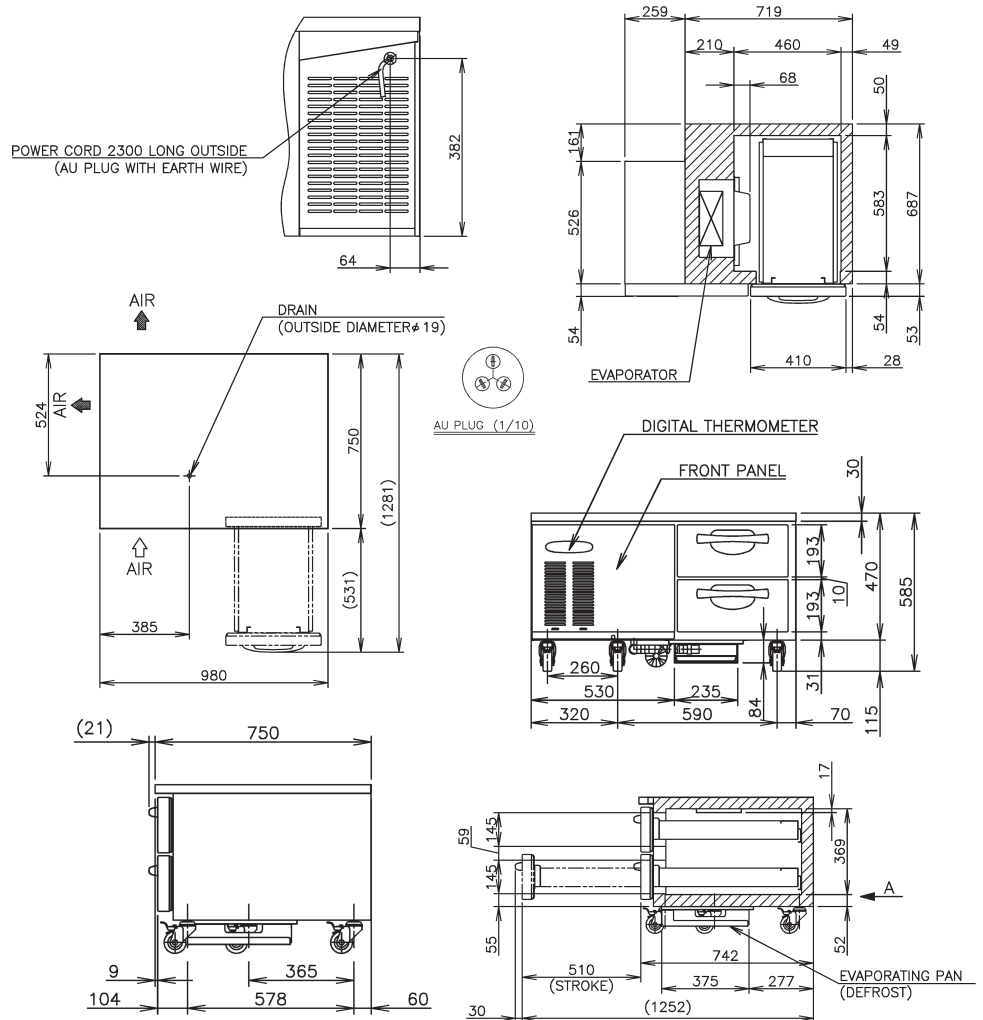

PRODUCT SPECIFICATION



Exterior	Precoated Steel, Galvanized Steel (Rear/Bottom) Stainless Steel (Door, Front Panel)
Interior	Precoated Steel, Stainless Steel(Door)
Max Storage Capacity	85L
Temperature Control	Microprocessor controlled Adjustable from -6 to 12°C
Drain Evaporator Pan	Fin & Tube type
Outside Dimensions	980mm (W) x 750mm (D) x 585mm (H)
Inside Dimensions	460mm (W) x 583mm (D) x 369mm (H)
Refrigeration System	Forced Air Circulation
Weight Net/Gross (kg)	65 / 74
AC Supply Voltage	1 PHASE 220-240V 50Hz
Amperage	Rated: 2.0A
Refrigerant	R134a / 110g
Operating Conditions	Ambient Temp.: 5-43°C Voltage Range: Rated Voltage \pm 6%



Descriptions and specifications are subject to change at any time, without notice. Illustrations for demonstration purposes.

Copyright © 2019 Hoshizaki Lancer Pty Ltd. All right reserved. E&OE Date: May 2019