

FEATURES

- Available in curved & square glass
- 2 width size options
- Works from 2-8 degrees temp range
- Easy to maintain & clean
- Removable back doors
- Stainless steel wire shelving racks
- LED lights
- Showcase your products with maximum exposure
- Superb for installing on top of counters
- 2 Years parts & labour warranty



700mm: TY110L
900mm: TY130L



700mm: TF120L
900mm: TF160L

| INFORMATION | TY110L | TY130L | TF120L | TF160L |
|--------------------------|-------------------------|-------------------------|-------------------------|-------------------------|
| Capacity | 110L | 130L | 120L | 160L |
| Power | 226W | 242W | 226W | 242W |
| Voltage | 220~240V/50Hz | 220~240V/50Hz | 220~240V/50Hz | 220~240V/50Hz |
| Working Temp | +2~+8°C | +2~+8°C | +2~+8°C | +2~+8°C |
| Ambient Temp | 43°C | 43°C | 43°C | 43°C |
| Dimensions(mm) | W700 x D560 x H670,63kg | W900 x D560 x H670,70kg | W700 x D560 x H670,65kg | W900 x D560 x H670,75kg |
| Packaging Dimensions(mm) | W784 x D641 x H790,87kg | W984 x D641 x H790,94kg | W784 x D641 x H790,89kg | W984 x D641 x H790,99kg |



2 YEARS WARRANTY ON ALL PARTS & LABOUR
* EXTRA 2 YEARS WARRANTY ON PARTS WHEN YOU REGISTER WITH US ONLINE

TY110L/TY130L

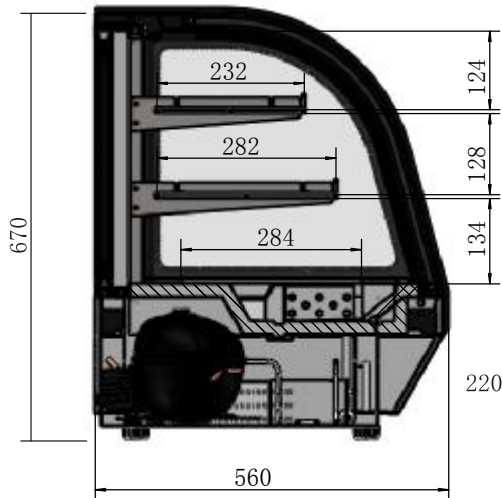

TF120L/TF160L

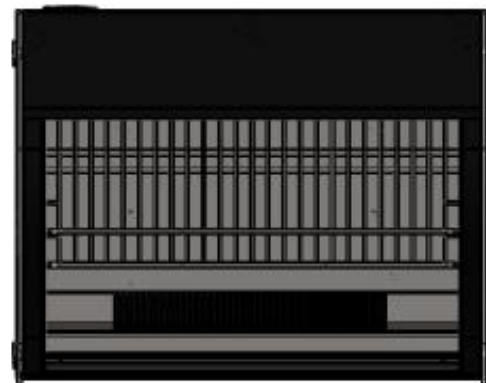
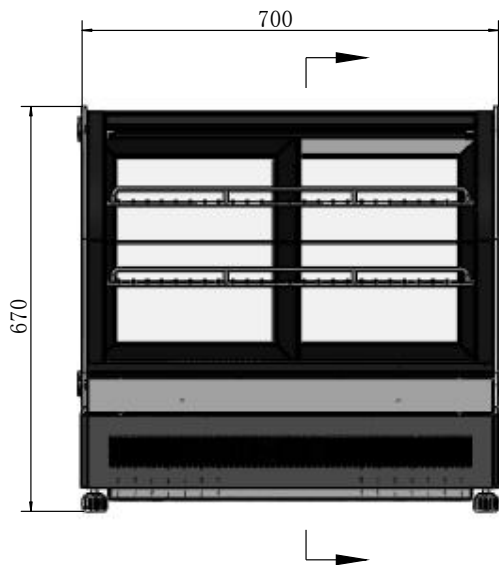
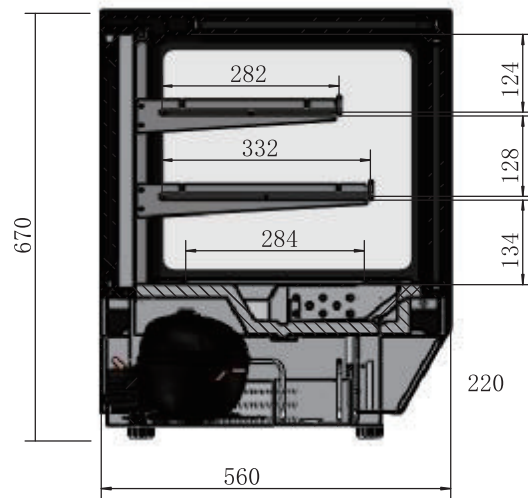

CE MEPS



+



2 YEARS WARRANTY ON ALL PARTS & LABOUR
* EXTRA 2 YEARS WARRANTY ON PARTS WHEN YOU REGISTER WITH US ONLINE