

FEATURES

- Single door 410 LT Capacity refrigerators & freezers
- Double door 900 LT Capacity refrigerators & freezers
- Single door only 600mm wide / double door only 1200mm wide
- Top mounted units
- Stainless steel exterior and interior
- Heavy duty Embraco compressor
- 40 degree working ambient temperature
- Dixell Italian digital temperature controls
- Self-closing doors
- White PVC heavy duty shelving
- Heavy duty castors for easy mobility
- Recessed door handle
- Safety door lock
- Magnetic door gaskets
- Designed to work in the busiest kitchens
- Tailor made to handle the Australian climate
- Needs to be 100mm off the wall for breathing space



YBF9206
YBF9207



YBF9218
YBF9219



INFORMATION	YBF9206	YBF9207	YBF9218	YBF9219
Capacity	410L	410L	900L	900L
Power	330W	454W	408W	741W
Voltage	220~240V/50Hz	220~240V/50Hz	220~240V/50Hz	220~240V/50Hz
Working Temp	-2°C~+8°C	-22°C~-17°C	-2°C~+8°C	-22°C~-17°C
Ambient Temp	40°C	40°C	40°C	40°C
Dimensions(mm)	W600 x D745 x H1950,90kg	W600 x D745 x H1950,90kg	W1200 x D745 x H1950,135kg	W1200 x D745 x H1950,135kg
Packaging Dimensions(mm)	W640 x D774 x H2050,100kg	W640 x D774 x H2050,100kg	W1240 x D774 x H2050,145kg	W1240 x D774 x H2050,145kg



2 YEARS WARRANTY ON ALL PARTS & LABOUR
* EXTRA 2 YEARS WARRANTY ON PARTS WHEN YOU REGISTER WITH US ONLINE

YBF9206 / YBF9207

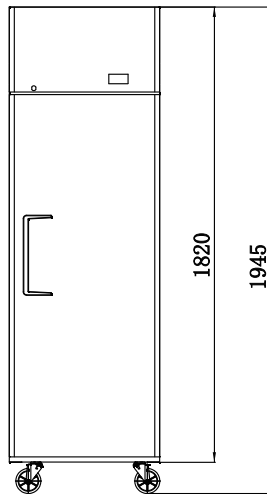
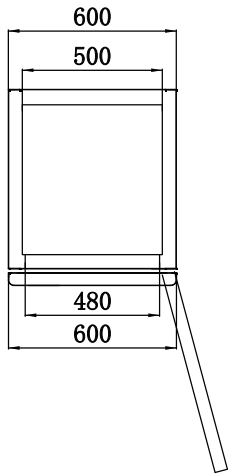

Side View

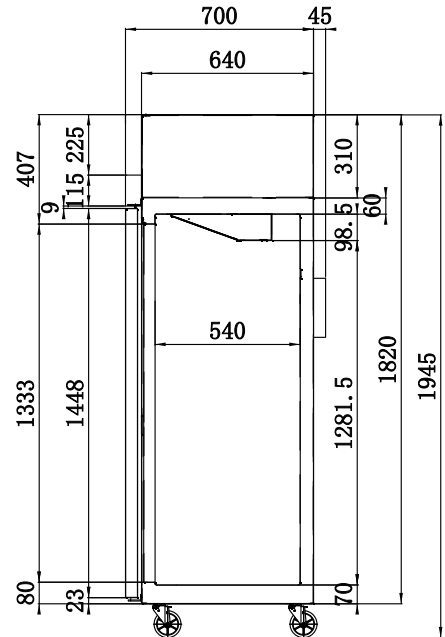

YBF9218 / YBF9219

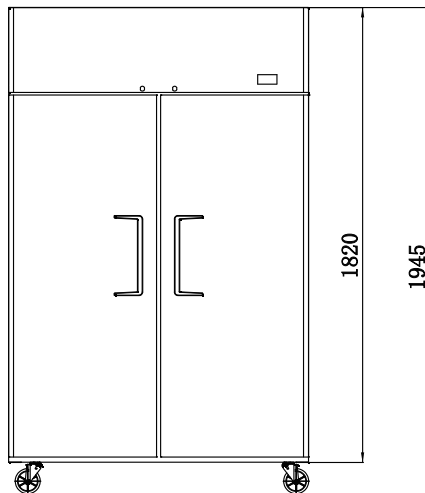
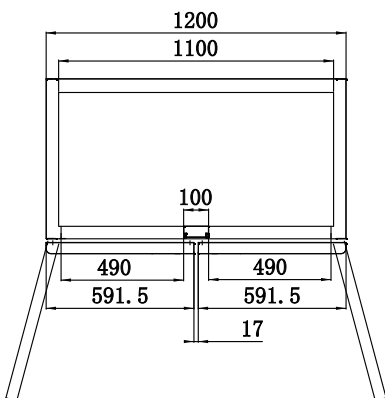

Side View

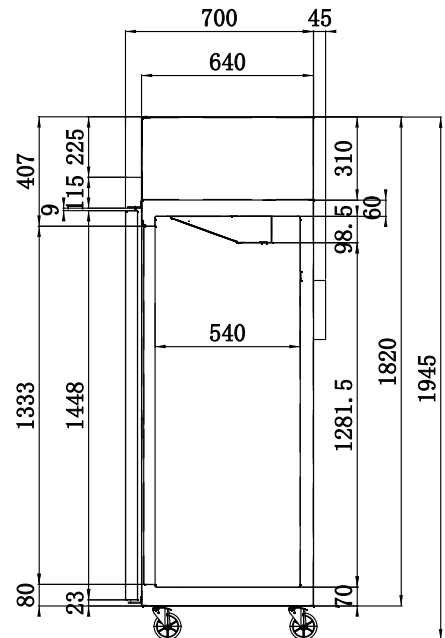

2 YEARS WARRANTY ON ALL PARTS & LABOUR
* EXTRA 2 YEARS WARRANTY ON PARTS WHEN YOU REGISTER WITH US ONLINE