

## FEATURES

- *Stainless steel interior and exterior with galvanised back panel*
- *Gas: R134A for Fridges*
- *Insulation Foam: C5H10,ODP, Zero emissions*
- *43°C ambient working temperature*
- *Come with wired mid shelf*
- *Castors as standard*
- *All European parts, Embraco compressor, EBM fan motor*
- *Fan-Forced Cooling*
- *Auto-defrost function*
- *Carel or Dixell digital controller*
- *Allow 100 mm clearance for air ventilation*



YPF9020



YPF9030



YPF9040



INFORMATION	YPF9020	YPF9030	YPF9040
Capacity	220L	300L	390L
Power	300W	350W	400W
Voltage	220~240V/50Hz	220~240V/50Hz	220~240V/50Hz
Working Temp	-2°C~+8°C	-2°C~+8°C	-2°C~+8°C
Ambient Temp	43°C	43°C	43°C
Dimensions(mm)	W1200 x D600 x H838,71kg	W1500 x D600 x H838,74kg	W1800 x D600 x H838,81kg
Packaging Dimensions(mm)	W1254 x D654 x H867,86kg	W1554 x D654 x H867,100kg	W1854 x D654 x H867,111kg



2 YEARS WARRANTY ON ALL PARTS & LABOUR  
 \* EXTRA 2 YEARS WARRANTY ON PARTS WHEN YOU REGISTER WITH US ONLINE

# COMPACT UNDERCOUNTER REFRIGERATORS

YPF9020

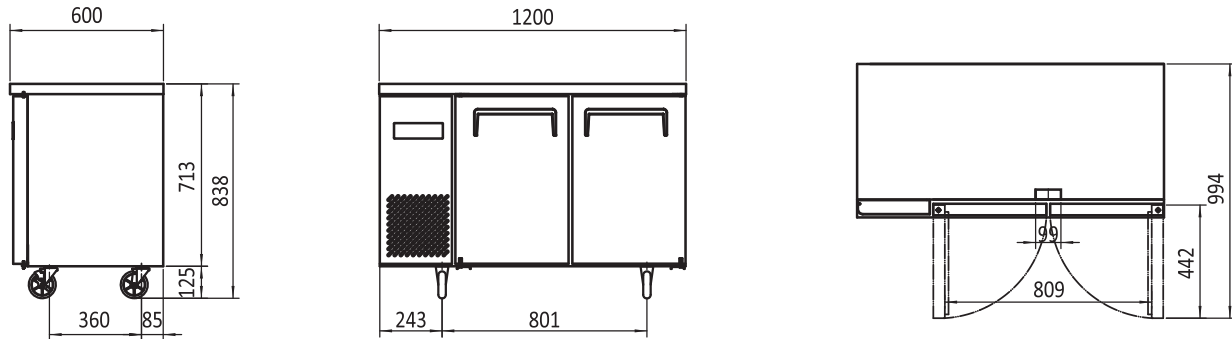

YPF9030

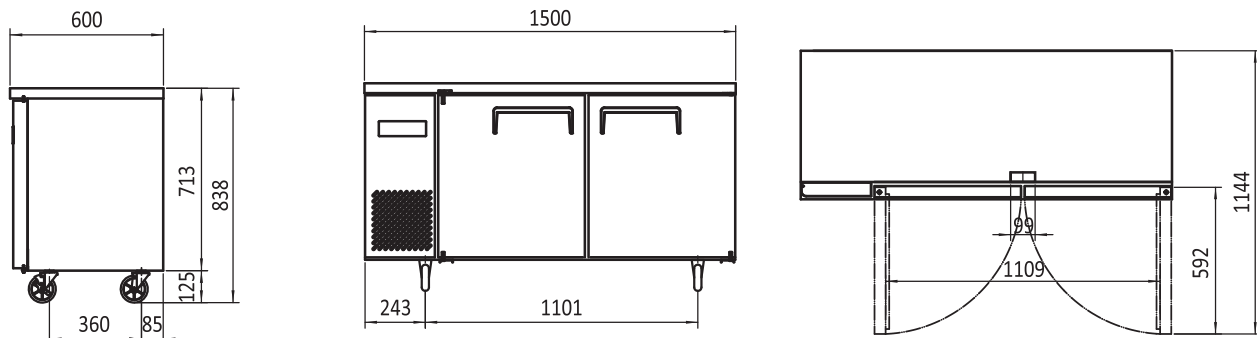

YPF9040

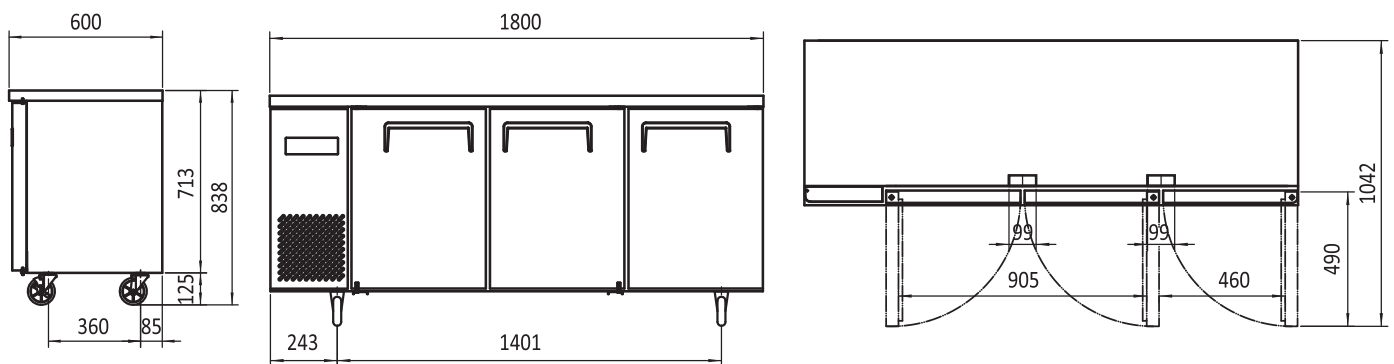

2 YEARS WARRANTY ON ALL PARTS & LABOUR  
\* EXTRA 2 YEARS WARRANTY ON PARTS WHEN YOU REGISTER WITH US ONLINE