

W.CVS.S.10 / W.CVS.S.15



Snackmaster Conveyor Oven

The Snack Master Small is sized to fit on any benchtop, allowing for perfect toasting.

This super-efficient, easy loading compact conveyor is complete with belt extension for easy loading, individual controls for temperature adjustments and features turbo fan cooling. Toasting has never been easier.

Product Information:

- Ideal for toasting/cooking open snacks and a variety of other foods
- Long life metal elements for continuous use
- 300mm long cooking conveyor for easy loading
- Fan cooled dial controls and fan forced heat technology
- Fully insulated top and body retains heat inside where it should be
- Independent temperature controls for top and bottom elements
- Variable speed belt control with automatic tensioning
- Stainless steel construction

Specifications:

Model W.CVS.S.10
Height 465mm
Width 1000mm
Depth 445mm
Weight 46kg
Power 2.4kW
 10A plug & lead fitted

Model W.CVS.S.15
Height 465mm
Width 1000mm
Depth 445mm
Weight 46kg
Power 3.6kW
 15A plug & lead fitted

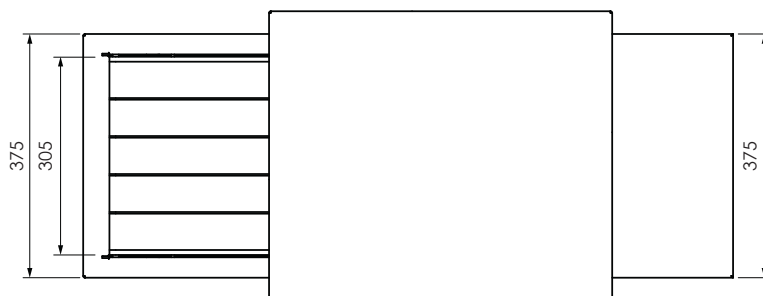

Top View

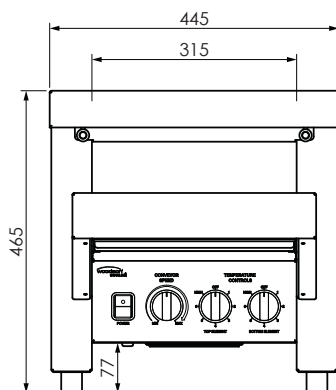

Front View

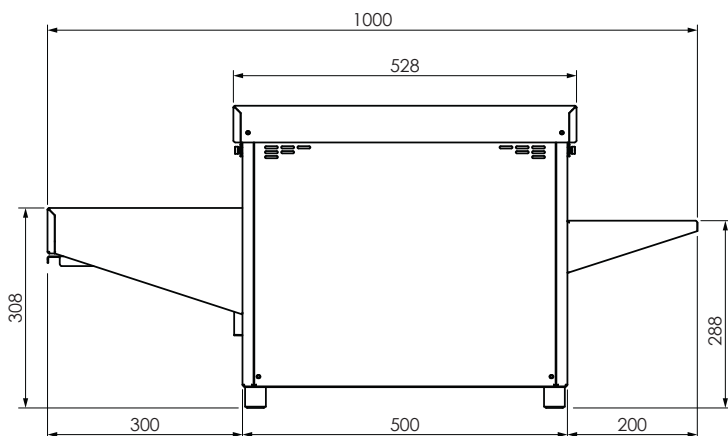

Side View

Due to continuous product research and development, the information contained herein is subject to change without notice.

Revision: 28/05/2019

www.stoddart.com.au

www.stoddart.co.nz