



## CHC282E

### Cook & hold oven

#### CONSTRUCTION FEATURES

- Two separately controlled compartments with radiused corners
- Total thermic insulation with rock or glass wool
- Long lasting frontal seals made up of food grade of high heat resistance
- Static heating provided by low consumption wire heating element that coils up all the chamber
- Snap-shut door
- Mounted on four 150mm diameter castors, two of wich with brake
- All-around rubber bumpers
- Tightness cavity with radiuses corners, built-in drip tray and drainage system

#### FUNCTIONAL FEATURES

- Electronic control panel of temperature, time, core probe and  $\Delta t$  with LCD touch-screen
- Operating temperature 30°C ÷ 160°C
- End-of-cycle buzzer
- Chamber with safety thermostat
- Internal drain for easy cleaning
- Condensation drain tray
- Delayed start timer

#### STANDARD SUPPLY

- Multipoint core probe with the possibility to register 30 different temperatures and save them in the HACCP report (available only with USB port device)
- Glazed doors plus lighting
- Removable GN2/1 and GN1/1 tray racks

#### OPTIONS & ACCESSORIES

- USB port saving device HACCP
- Automatic door lock

**MODULINESRL**

Via dell'Industria 11, Z.I. San Giacomo di Veglia 31029 Vittorio Veneto (TV) - ITALY  
 tel. +39 0438 5063 - fax +39 0438 912 323 - info@moduline.it - www.moduline.it



moduline

**TECHNICAL  
INSTALLATION  
DIAGRAM**

Electricity supply  
cable inlet 

Chamber drain 

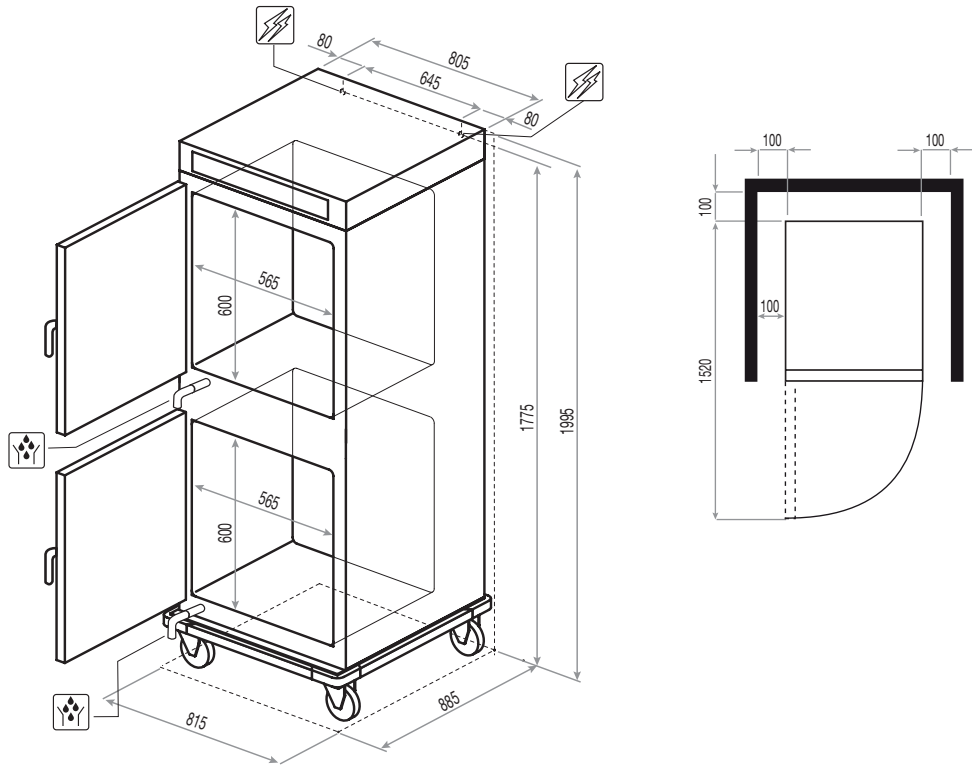

**Overall dimensions  
(W x D x H) - mm**

815 x 885 x 1995h

**Working  
temperature [°C]**

30÷160

**Trays capacity  
(-- ) space between**

8 + 8 x GN 2/1  
16 + 16 x GN 1/1 (70)

**Containers capacity  
distance [mm]**

8 + 8 x GN 2/1 (70)  
16 + 16 x GN 1/1 (70)

**Power  
[kW]**

3 + 3

**Product max  
capacity [kg]**

55 + 55

**Power supply**

AC 230V 50 Hz

**Rated voltage  
[Vac]**

230

**Total input  
[Kw]**

3 + 3

**Amps.  
[A]**

13 + 13

**Connecting wire  
min. section (type  
H07 RN-F) [mm<sup>2</sup>]**

3 x 1,5

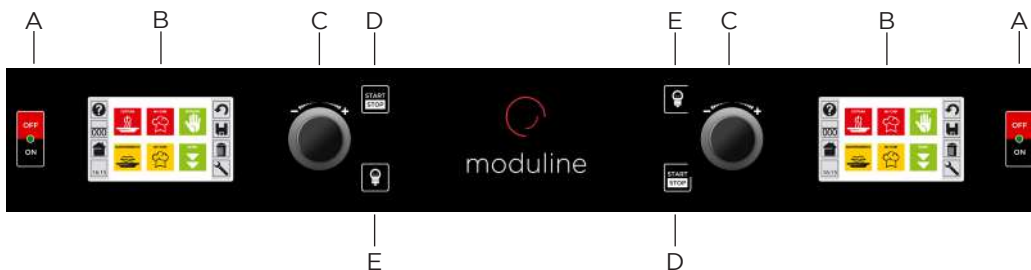

- A ON/OFF switch
- B Display Touch Screen
- C Setting knob and select "ENTER"
- D "START/STOP" button
- E Chamber light button

**MODULINESRL**

Via dell'Industria 11, Z.I. San Giacomo di Veglia 31029 Vittorio Veneto (TV) - ITALY  
tel. +39 0438 5063 - fax +39 0438 912 323 - info@moduline.it - www.moduline.it