



VERRO SERIES: VTF-451

Single Pan Turbo Fryer

Project: _____ Item: _____



VTF-451

Standard Features:

- AISI 304 Grade Stainless Steel
- Heavy Duty Complete Stainless-Steel Cabinet Frame
- Efficient Target Burner
- +/- 3° Degree Temperature Recovery Differential
- 2mm Thick Stainless Steel Pan
- Over-Temperature Safety Cut Out Switch
- 21.3 Litre Oil Capacity
- Complete with Two Baskets, Fish Plate and a Night Cover
- Piezo ignition and Flame Failure device are fitted as standard
- Easy access to all components for servicing and adjustment
- 24-month warranty

Options:

- Castors
- Plinth mounted
- Natural or LP gas

Specifications:

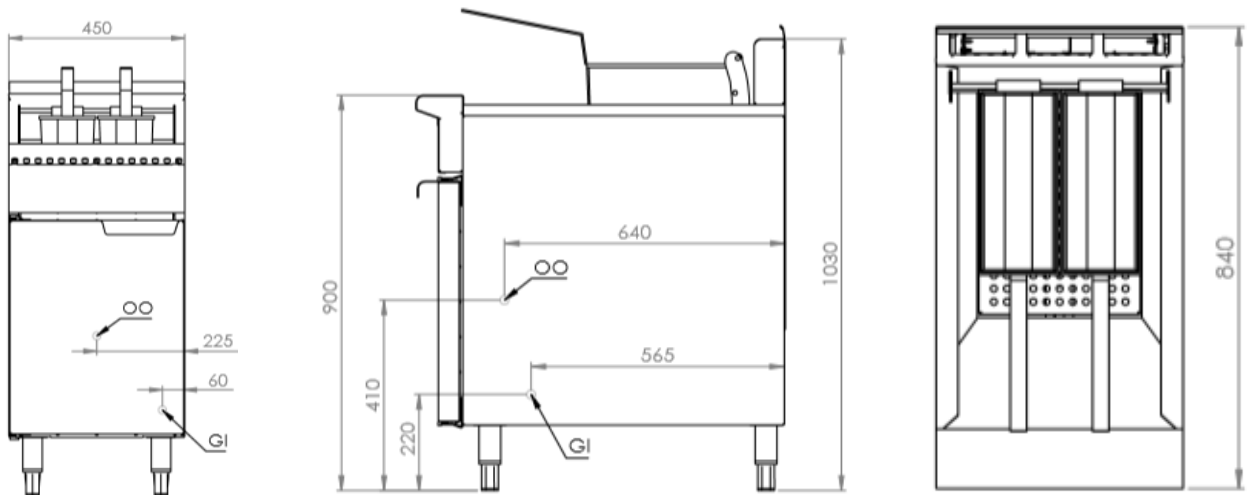

MODEL	LENGTH (mm)	DEPTH (mm)	HEIGHT (mm)	GAS CONSUMPTION (Mj/h)	
				NG	LPG
VTF-451	450	840	1030	87	87

Connections:

GAS (GI) (BSP)	WASTE (OO) (BSP)	SUPPLY PRESSURE (kPa)	
		NG	LPG
¾" (M)	1 ¼" (M)	1.0	2.6

- Regulator is included in the unit
- **Must** be installed by an authorised installer

Due to ongoing Product Development, Product Improvement and Research, B+S Commercial Kitchens reserves the right to alter specification without notice.



B+S Commercial Kitchens
 57 Plateau Road Reservoir VIC 3073 Australia | +61 3 9469 4754
 info@bscommercialkitchens.com | www.bscommercialkitchens.com

